

Owners Manual

R0 Drinking Water System

R0-UX5

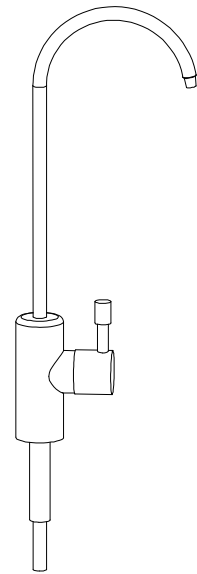
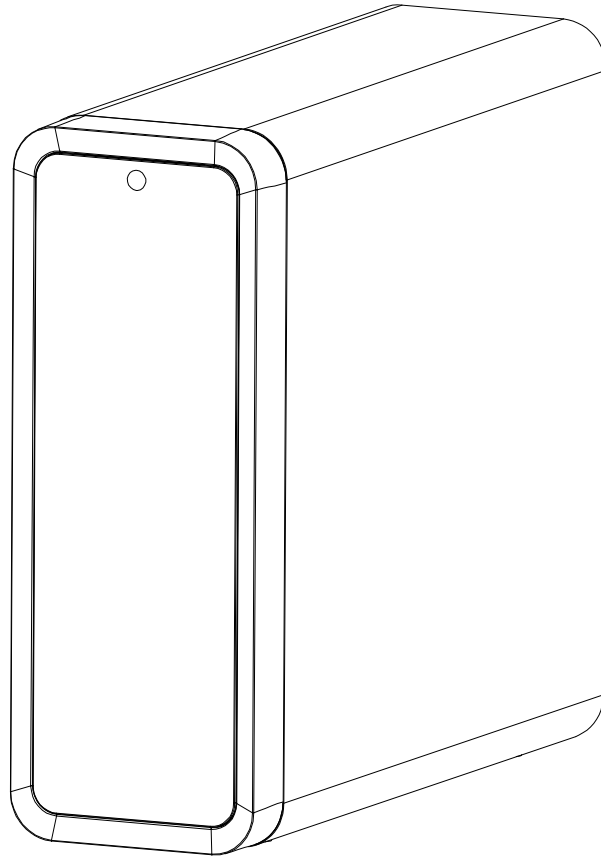

- ❑ Please read carefully before proceeding with installation. Your failure to follow any attached instructions or operating parameters may lead to the product's failure. Keep this manual for future reference.
- ❑ Do not use the water that is microbiologically unsafe or of unknown quality without adequate disinfection before or after the system.
- ❑ Test the water periodically to verify that the system is performing satisfactorily.

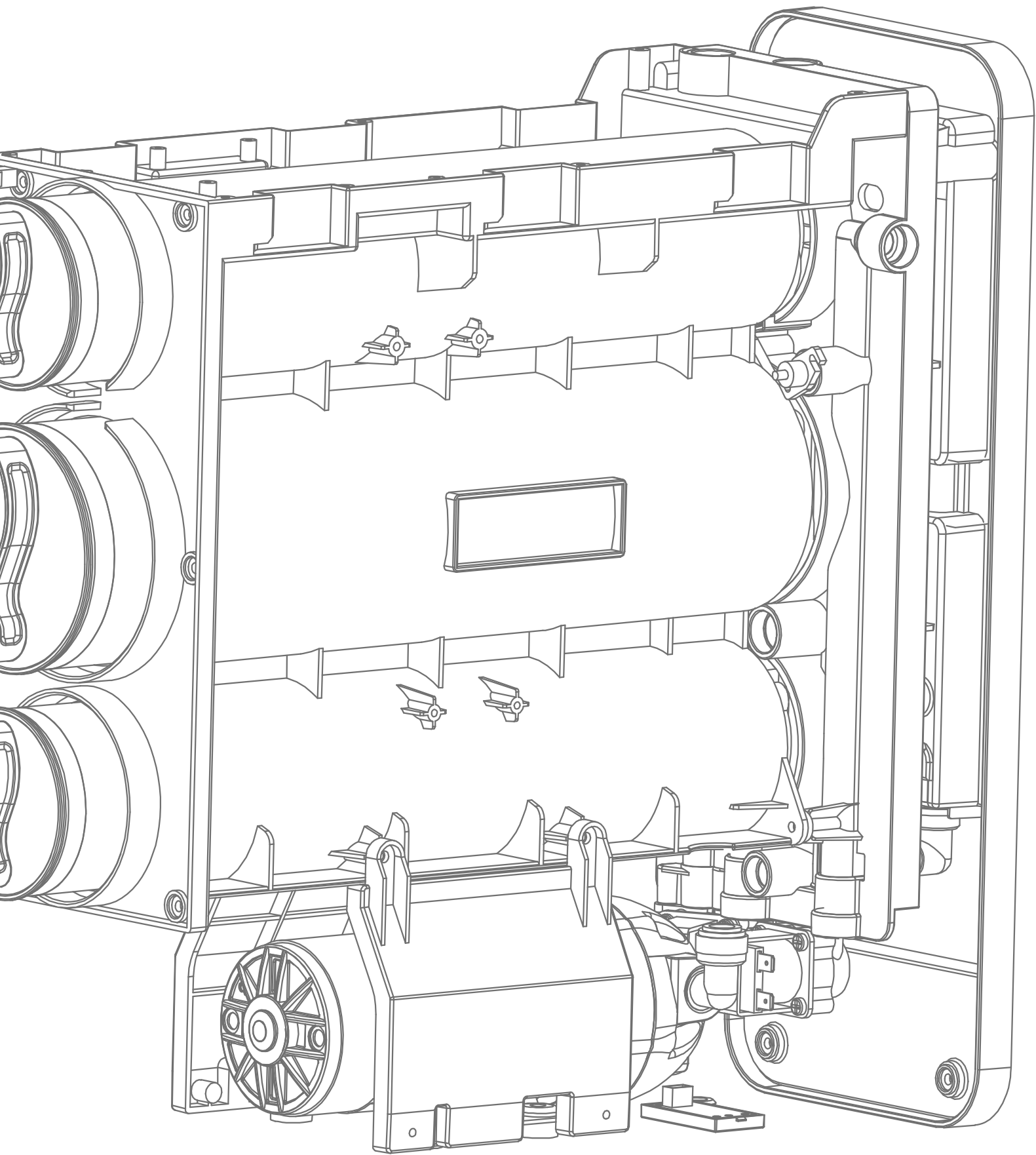

TABLE OF CONTENTS

<i>READ THIS PAGE FIRST</i>	4
<i>RO SYSTEM SPECIFICATIONS</i>	5
<i>UNPACK & INSPECT YOUR RO SYSTEM</i>	7
<i>RO SYSTEM DIMENSIONS</i>	8
<i>CHECK MODEL LABEL AND SERIAL NUMBER</i>	8
<i>OVERVIEW OF THE RO SYSTEM'S COMPONENTS</i>	9
<i>FLOW SEQUENCE</i>	10
<i>ELECTRICAL SCHEMATIC</i>	10
<i>PARTS BREAKDOWN</i>	11
<i>INSTALLATION RO UNIT</i>	12
<i>LED DISPLAY & TOUCH KEYS PROGRAMMING GUIDE</i>	16
<i>SERVICE AND MAINTENANCE</i>	18
<i>TROUBLE SHOOTING GUIDE</i>	20

READ THIS PAGE FIRST

BEFORE STARTING INSTALLATION

▶ You must read and understand the contents of this manual before installing or operating your RO system.

Personal injury or property damage could result if you fail to follow instructions in this manual.

▶ This system and its installation must comply with state and local regulations. Check with your local public works department for plumbing and sanitation codes. Local codes should be followed in the event the codes conflict with any content in this manual.

▶ This RO system must be operated on pressures between 14 psi to 58 psi. If the water pressure is higher than 58 PSI, use a pressure reducing valve in the water supply line to the RO system.

▶ This unit must be operated at temperatures between 5°C - 38°C (41°F and 110°F)

▶ Do not use this RO system on hot water supplies.

▶ Do not install this unit where it may be exposed to wet weather, direct sunlight, or temperatures outside of the range specified above.

▶ The appliance is only to be used with the power supply unit provided with the appliance.

▶ The appliance must only be supplied at safety extra low voltage corresponding to the marking on the appliance.

▶ Do not use water that is microbiologically unsafe without adequate disinfection before or after this system.

▶ This publication is based on information available when approved for printing. Continuing design refinement could cause changes that may not be included in this publication.

▶ This appliance can be used by children aged from 8 years and above and persons with reduced physical, sensory or mental capabilities or lack of experience and knowledge if they have been given supervision or instruction concerning use of the appliance in a safe way and understand the hazards involved.

▶ Children shall not play with the appliance.

▶ Cleaning and user maintenance shall not be made by children without supervision.

INSTALL NOTES & SAFETY MESSAGES

Watch for the following messages in this manual:

EXAMPLE:

NOTE

Check and comply with your state and local codes. You must follow these guidelines.

EXAMPLE:



CAUTION

Disassembly while under pressure can result in flooding.

EXAMPLE:



WARNING

Electrical Shock Hazard! Unplug the unit before removing the cover or accessing any internal control parts.

RO SYSTEM SPECIFICATIONS

RO-UX5

Model		RO-UX5-400G	RO-UX5-600G	RO-UX5-800G	RO-UX5-1000G
Water Supply		Municipal Water			
Feed Line Pressure		0.1MPa~0.4MPa			
Faucet Flow		1 L/min	1.5 L/min	2 L/min	2.5 L/min
Salt Rejection		≥93%			
Recovery		≥55%	≥65%	≥65%	≥65%
Feed Water Temperature		5~38 C			
Ambient Humidity		≤90%			
Sound Level		≤55dB		≤60dB	
Electrical	Input	100~240V AC 50/60Hz 3A			
	Output	24V DC 4A		36V DC 3.3A	
	Power Used	65W	85W	96W	110W
Membrane	Type	Thin Film Composite Membrane			
	Rating	400 GPD	600 GPD	800 GPD	1000 GPD
Connection	Faucet	3/8" Quick Connect			
	Inlet	3/8" Quick Connect			
	Drain	3/8" Quick Connect			
	Power	Quick Connect Power Cable			
Accessory		Faucet & Installation Kit Included			
Gross Weight		13 Kg			
Product Dimension(WxDxH)		431×161×477 mm			
Carton Dimensions(WxDxH)		535×295×525 mm			

- Salt rejection and product flow are variable and can be effected by temperature and feed water conditions.

Model	Stage 1	Stage 2	Stage 3	Faucet
RO-UX5	CPF Filter	Reverse Osmosis Membrane	Post Carbon Filter	SS Steel
	PP+Carbon Block	400/600/800/1000 GPD	Carbon Block	

PERFORMANCE & TECHNICAL INFORMATION

The performance of the RO-UX5 system can be characterized and judged by the quality of the water produced by the system. By measuring the contaminant removal performance and flow rates of the system, its operating status can be easily evaluated.

Factors Which Affect Performance

Performance of the reverse osmosis membrane is affected by several factors which must be considered when judging the condition of the system. The main factors which affect system performance are pressure, temperature, total dissolved solids level, recovery and PH.

Pressure

Water pressure affects both the quantity and quality of the water produced by the RO membrane. Generally, the more water pressure, the better the performance of the system.

Temperature

The reverse osmosis process slows with decreasing temperature. To compensate, a temperature correction factor is used to adjust the actual performance of the RO membrane filter to the standard temperature of 77°F (25°C). This allows the performance of the unit to be accurately gauged against published standards. Temperature does not affect the concentrate flow rate.

Total Dissolved Solids

The minimum driving force which is necessary to stop or reverse the natural osmosis process is termed osmotic pressure. As the total dissolved solids level of the feed water increases, the amount of osmotic pressure increases and acts as back pressure against the reverse osmosis process. Osmotic pressure becomes significant at TDS levels above 500 mg/L(ppm).

Hardness

Hardness is the most common membrane foulant. If ignored, this relatively harmless component of feed water will scale a membrane over time. Use of a softener will reduce the fouling effect on a membrane. One way to detect too much hardness in the feed water is the weight of a membrane installed for a period of time. A fouled membrane(dried) will weigh significantly more than a new membrane. The increase in weight is a result of precipitated hardness inside the membrane.

Iron

Iron is another common membrane foulant. There are a variety of types of iron, some of which cannot be removed by an iron filter. Clear water iron can be removed more effectively by a softener. Particulate iron can be removed more effectively by a 1 micron filter. Organic-bound iron can be removed only by activated carbon or macroporous anion resin. If there is enough iron to exceed the EPA secondary drinking water standard and softening the water is not an option and the iron is soluble, then an iron filter is appropriate. If none of these are an option, then regular replacement of membranes will have to be accepted.

Product Water Recovery

Product water recovery plays an important role in determining membrane and system performance. Recovery refers to the amount of water produced in relation to the amount of water sent to drain. The standard calculation is:

$$\% \text{Recovery} = \text{Product Water} \div (\text{Product Water} + \text{Waste Water}) \times 100$$

The system uses a flow control assembly to restrict the flow of waste water to the drain. This restriction helps maintain pressure against the membrane. The sizing of the flow control assembly determines the recovery rating of the system. The system is manufactured with a recovery rating designed to be more than 50%. Depending on temperature, pressure and tolerances the actual recovery value may be slightly different for each system.

UNPACK & INSPECT YOUR RO SYSTEM

Inspect the RO system for any shipping damage. If damage is found, notify the transportation company and request a damage inspection. Damage to cartons should also be noted.

Handle all components of the system with care. Do not drop, drag or turn components upside down.

The manufacture is not responsible for damages in transit. Small parts, needed to install the RO system, are in a parts box. To avoid loss the small parts, keep them in the parts bag until you are ready to install.

PACKAGE CONTENTS:

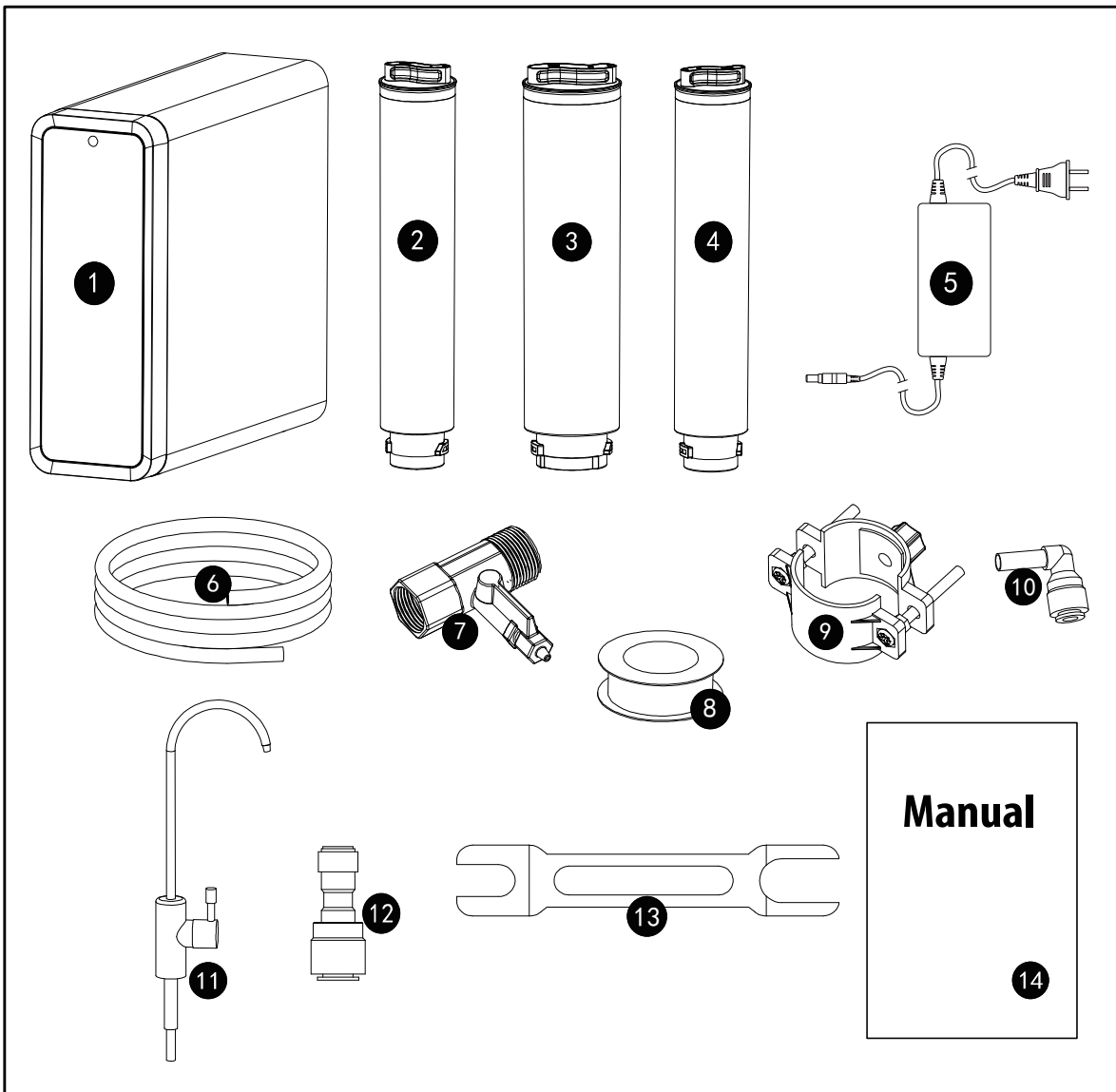

- 1. RO Module Assembly × 1
- 2. CPF Filter Cartridge × 1
- 3. RO Filter Cartridge × 1
- 4. CTO Filter Cartridge × 1
- 5. Power Transformer × 1

- 6. 3/8" Tubing × 1
- 7. Inlet 3-Way Valve(1/2") × 1
- 8. Thread Sealing Tape × 1
- 9. Drain Saddle(1/4") × 1
- 10. L-Connector 3/8"×1/4"Stem

- 11. SS Faucet × 1
- 12. Faucet QC Connector(1/4" to 3/8") × 1
- 13. Tubing Tool(1/4" & 3/8") × 1
- 14. User Manual × 1

RO SYSTEM DIMENSIONS

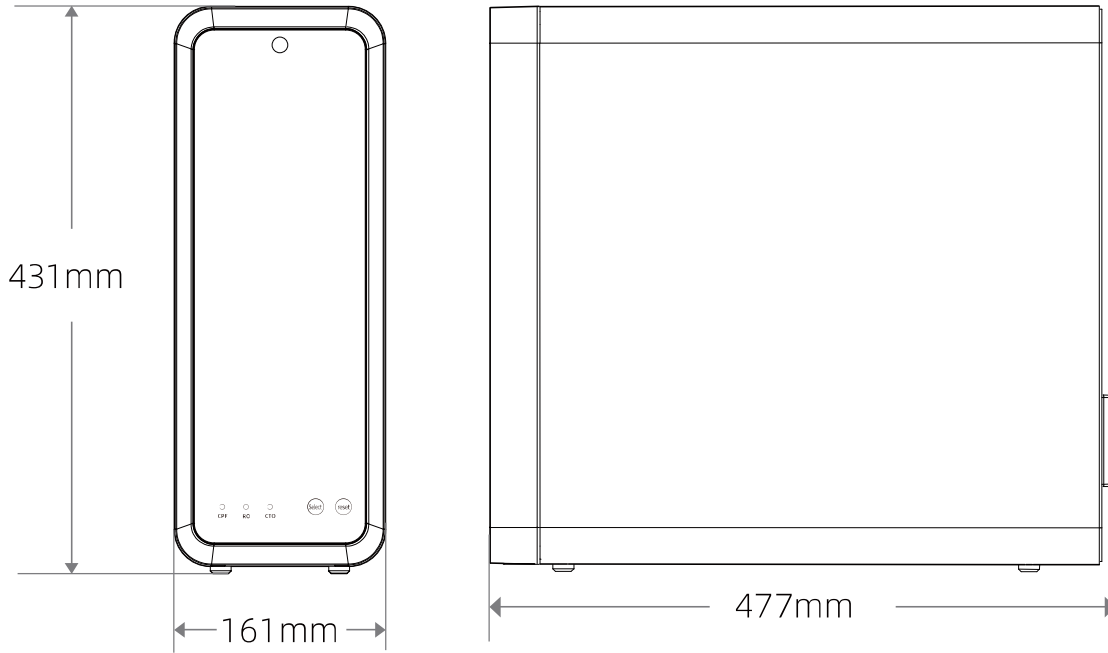

CHECK MODEL LABEL AND SERIAL NUMBER

The model label and serial number is located on the rear of the RO system housing. Check to make sure this RO system matches what you ordered. Serial numbers are important for troubleshooting.

The Model Label shows product number, product model and series number.

How to Read Series Number?

1040000859-W3G-02-0001

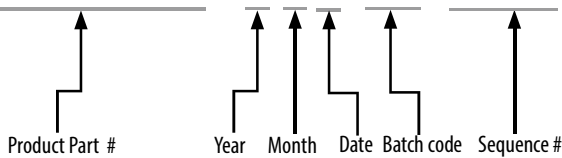

(1040000859): Product part #

(W)YEAR: "V" stand for year 2021, "W" stand for year 2022, "X" stand for year 2023...

(3)MONTH: 1(JAN), 2(FEB), 3(MAR), 4(APRIL), 5(MAY), 6(JUNE), 7(JULY), 8(AUG), 9(SEP), A(OCT), B(NOV), C(DEC)

(G)DATE: 1 2 3 4 5 6 7 8 9 (A)10 (B)11 (C)12 (D)13 (E)14 (F)15 (G)16 (H)17 (I)18 (J)19 (K)20 (L)21 (M)22 (N)23 (O)24 (P)25 (Q)26 (R)27 (S)28 (T)29 (U)30 (V)31

(02): Batch code

(0001): Sequence #

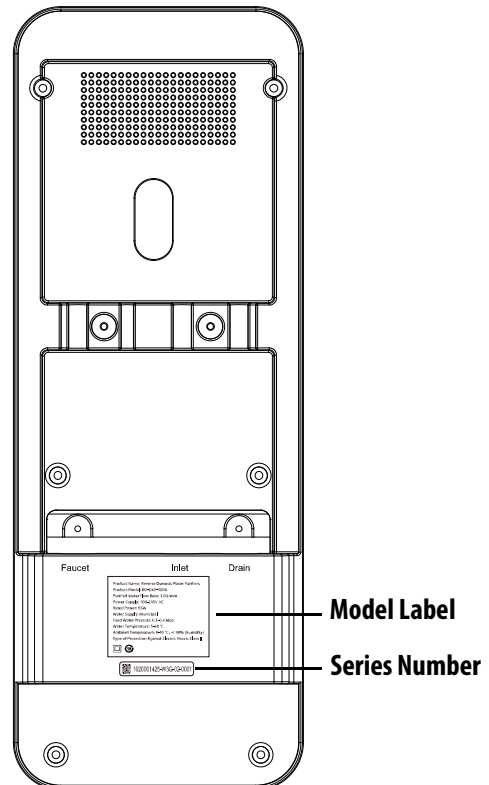

OVERVIEW OF THE RO SYSTEM'S COMPONENTS

1 RO Manifold Assembly

The manifold assembly serves as the functional hub of the RO manifold assembly by directing the flow through each of the system's main components.

2 Booster Pump

The booster pump built inside the manifold assembly improves the production rate and reduction of dissolved substances from water. It runs on electricity.

3 Automatic Solenoid Valve

The automatic solenoid valves are controlled by the program settings, it is used to control the water flow ON&OFF.

4 Low Pressure Switch

Low pressure switch ensure the boost pump running safely. It will shut off the power to avoid the boost pump "run dry" if feed water pressure is less than $0.5\text{Kg}/\text{cm}^2$.

5 High Pressure Switch

As the faucet is closed, the high pressure switch will shut off the power to stop running the boost pump.

6 CPF Filter

The CPF filter screens out particulate material, such as dirt, sand, or rust, which may clog the other filters in the system, also reduces chlorine which may damage the RO membrane filter. It must be regularly checked and/or replaced to prevent premature membrane failure and poor water quality.

7 Reverse Osmosis Membrane

The RO membrane (4) reduces dissolved substances and other microscopic impurities. It consists of a membrane envelope wound around a perforated tube. Product water diffuses through the membrane to the inside of the envelope where it flows to and is collected by the tube. Impurities are flushed away in the drain stream. The RO membrane featured in the RO-UX5 system offers exceptional contaminant rejection, application versatility and long life. The membrane material is sensitive to an attack by chlorine.

The activated carbon filter must be maintained properly to prevent premature failure of the RO membrane.

8 Post Carbon Filter

The post carbon filter adsorbs any residual tastes and odors just before the water is delivered through the faucet.

9 Faucet

The faucet allows the product water to be drawn from the system with a simple rotation of the handle.

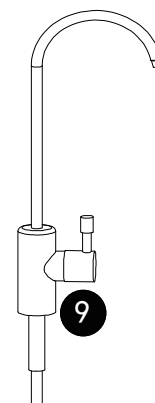
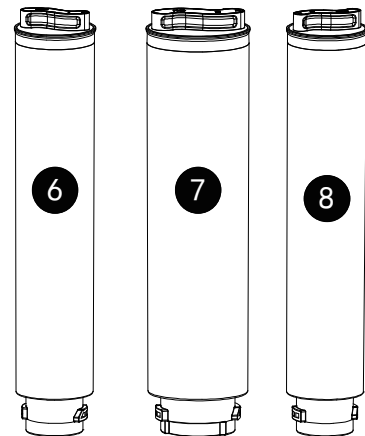
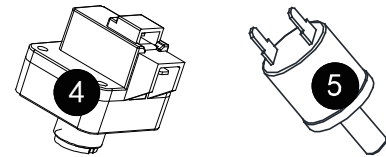
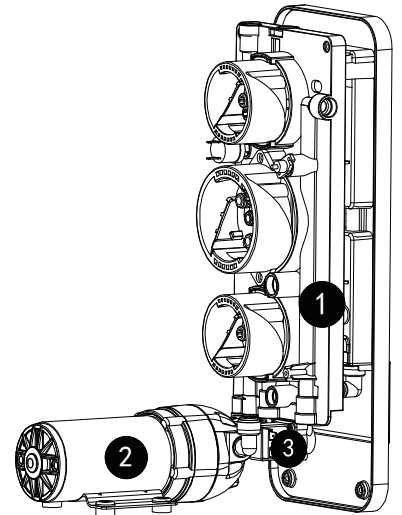

FLOW SEQUENCE

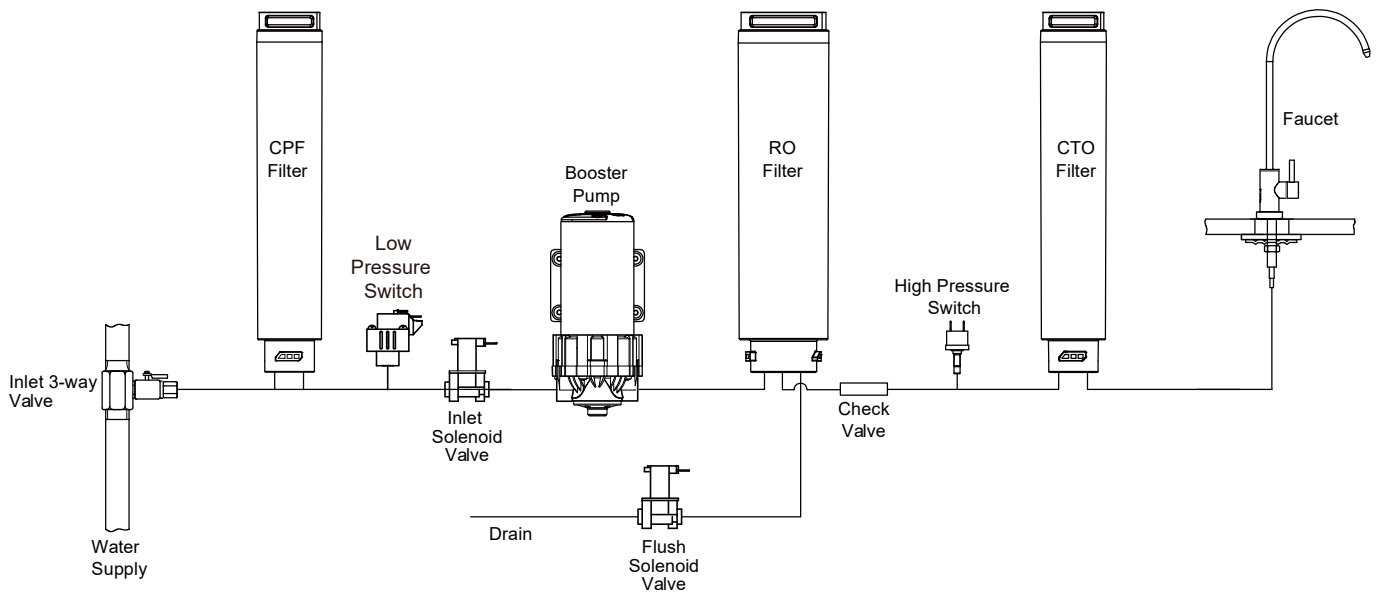

ELECTRICAL SCHEMATIC

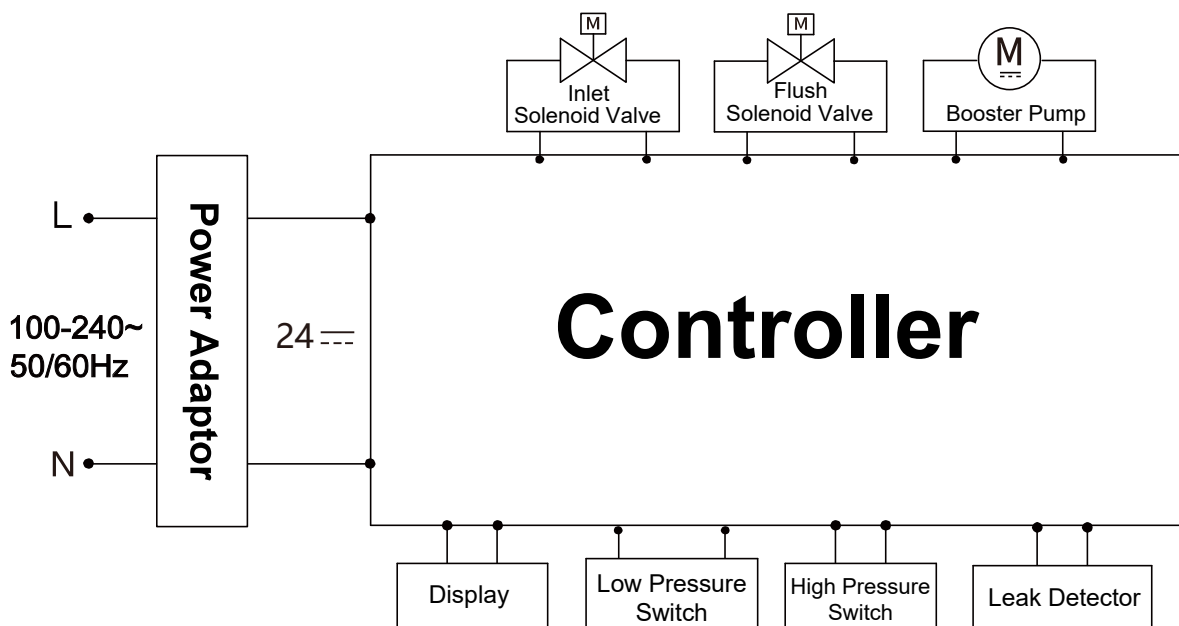

PARTS BREAKDOWN

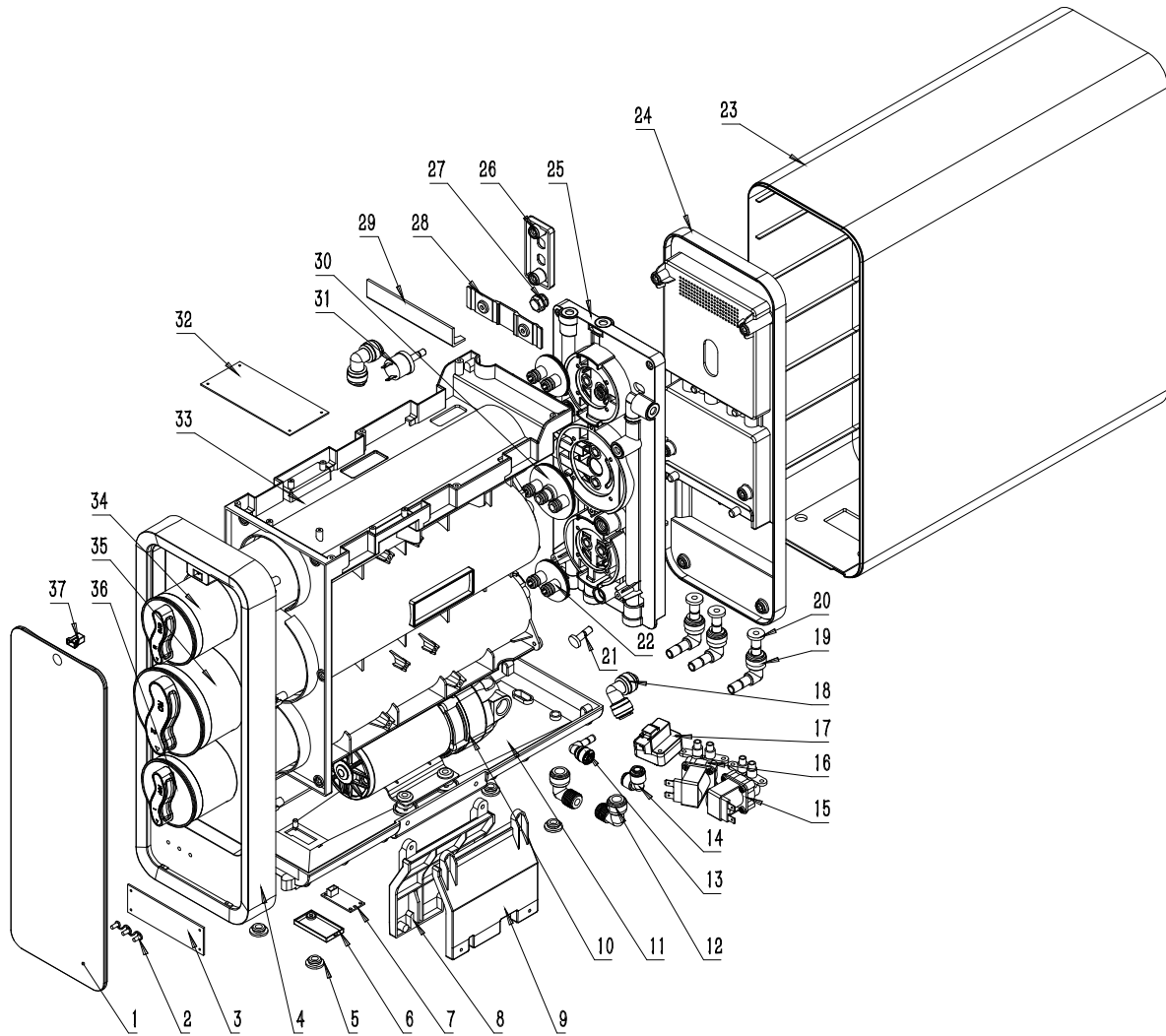

No.	Part #	Description	Qty
1	2020006509	Front Trim Cover	1
2	2020005580	Light Guide Column	3
3	3010021250	Display PCB	1
4	2020009085	Front Cover	1
5	3010012336	Silicone Pad	5
6	3010008863	Leakage Detector Cover	1
7	3010019051	Leakage Detector	1
8	3010008899	Left Support Bracket	1
9	3010008898	Right Support Bracket	1
10	3010020125	Booster Pump	1
11	2020005518	Bottom Base	1
12	3010012520	L-Connector 3/8"×3/8"Thread	2
13	3010012518	L-Connector 1/4"×1/4"Stem	1
14	3010008318	L-Connector 1/4"×1/4"	1
15	3010010317	Inlet Solenoid Valve	1
16	3010019995	Flush Solenoid Valve	1
17	1200000644	Low Pressure Switch	1
18	3010008319	L-Connector 3/8"×3/8"	2
19	3010012441	L-Connector 3/8"×3/8"Stem	3

20	3010012427	Plug 3/8"	3
21	3010012417	Plug 1/4"	1
22	3010008851	Filter Base	2
23	2020004861	Cabinet Cover	1
24	2020009086	Back Cover	1
25	3010008831	Integrated Water Manifold	1
26	3010008843	Power Cable Bracket	1
27	3010008329	Power Cable Wire	2
28	2020005732	Inlet&Outlet Fixture	1
29	3010008900	Pipe Line Fixture	1
30	3010008850	RO Filter Base	1
31	3010012572	High Pressure Switch	1
32	3010021251	Controller Board	1
33	3010008844	Filter Installation Guide	1
34	2010004098	CTO Filter	1
35	2010004099	RO Filter	1
36	2010004097	CPF Filter	1
37	3010012573	Push-button Switch	1

INSTALLATION RO UNIT

Before Installation

1. Check the accessories in the packing box and confirm if they are complete.
2. Shut off the water supply before installation.
3. Prepare some tools or equipments required for installation.

Suggested Installation Equipment

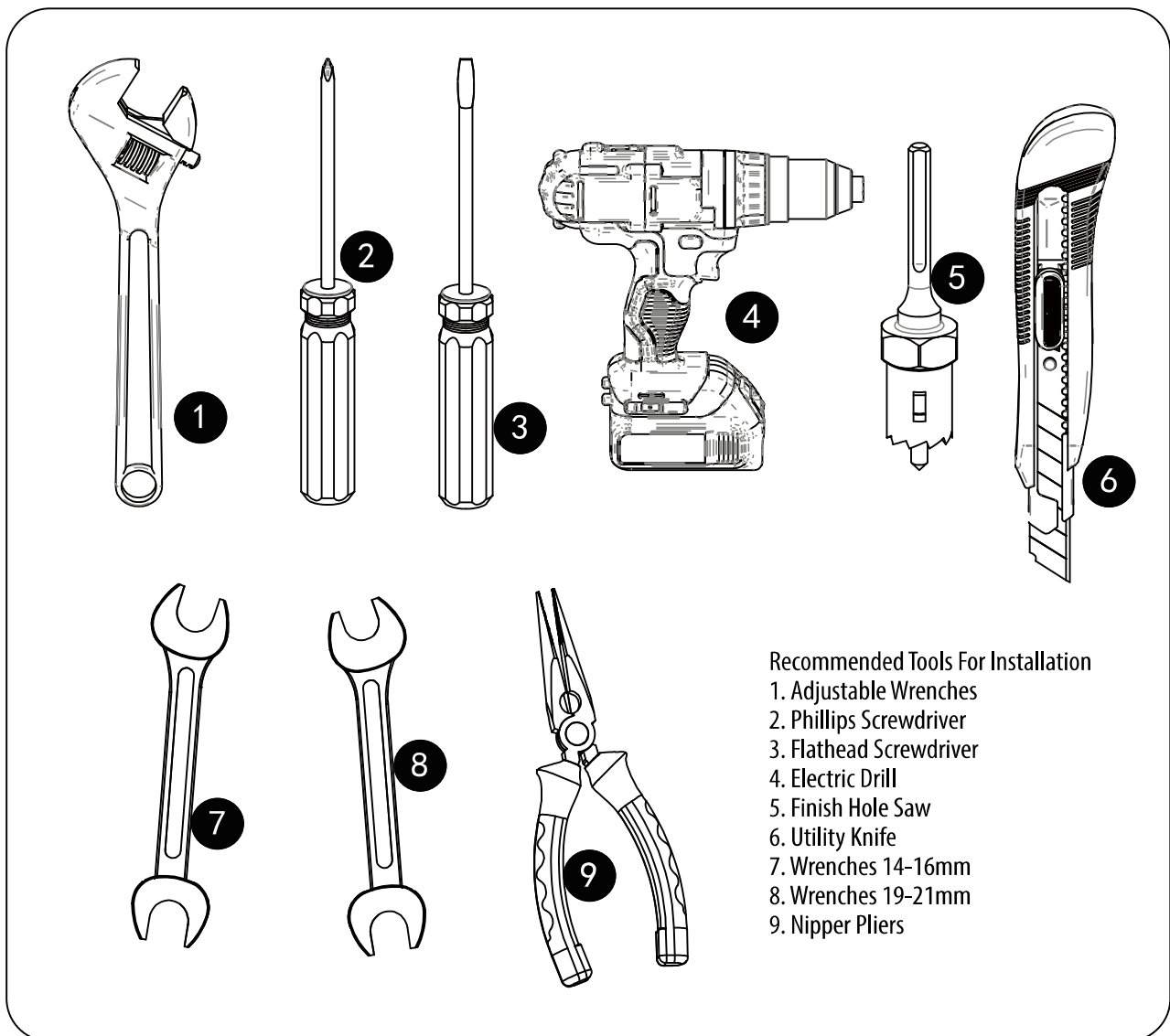

NOTE

As installations may vary, some extra plumbing connection fittings may be required.

Symbols for Tubing Connection

Please familiarize yourself with symbols on the back of RO system:

Faucet: Connect to RO water faucet.

Inlet: Connect to Feed Water.

Drain: Connect to Drain Water

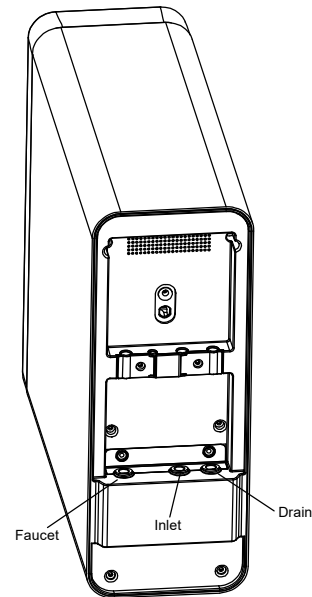

The following steps will enable you to install the system quickly and orderly. Some variation may be necessary depending on the installation.

Typical installations follow this sequence:

1. Select System Installation Locations
2. Faucet Installation
3. Install T-Adapter Valve on Water Supply
4. Connect System Drain
5. Install Filters Cartridges

Step-1 Select System Installation Locations

Important Considerations:

- Access to the bottom (undersink) of the faucet is required for attachment of product water line.
- There should be no undersink obstructions which would prevent smooth tubing runs to the inlet, faucet, drain connection, or RO module assembly.
- A nearby electrical power socket is required for operation, check the electrical power requirement on transformer.
- The RO system assembly is designed to be installed on counter top or under sink. It should be positioned such that there is access to an inlet water source and drain. The installation should also allow convenient access for servicing.
- Be sure the floor under the RO system is clean, level and strong enough to support the unit.

Step-2 Faucet Installation

Dispenser Faucet—The faucet is designed to be mounted on the rear lip of the sink. It may be installed in an existing sprayer attachment hole or in a hole drilled at the time of installation. It may also be mounted to an adjacent counter top. It should be positioned so that water is dispensed over the sink. A 12mm diameter hole is required.

1. Drill a $\phi 12\text{mm}$ hole at a proper location on the mounting surface, then take out the faucet from the accessory bag, install the faucet as the figure 1.
2. Tighten the SS screw and be sure to properly align the faucet.
3. Insert the faucet adaptor to the bottom of faucet.
4. Take out the 3/8" tubing from the accessory bag, cut it to proper length, attached one end to the faucet adaptor(3/8"), attach the another end to the "Faucet" port on RO module assembly, make sure the tubings are fully seated.

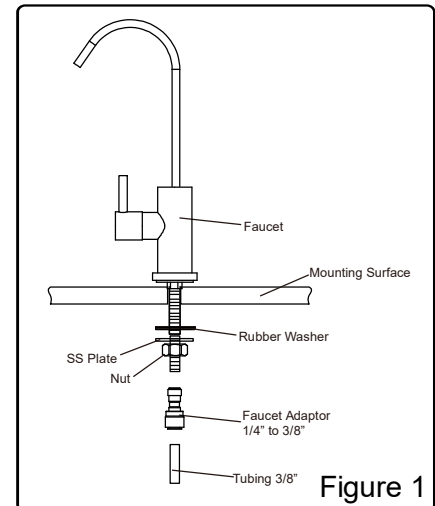

The RO system features reliable and convenient push-to-connect tubing connectors. Tubing is easily connected and disconnected from these fittings as follows.

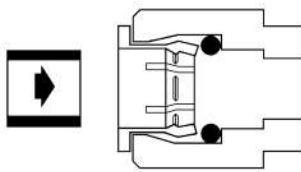

1. Simply push in tube to attach.

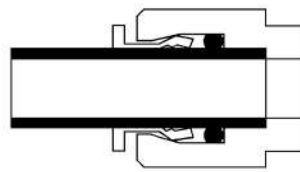

2. Tube is securely in position.

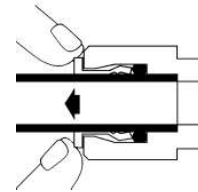

3. Push in collet from both sides to release tubing.

NOTE

Do not miss the blue secure clip for all tubing connection.

Connect:

Cut the tubing squarely with a sharp knife. Be careful not to crush the tubing. To avoid leaks, make sure the tubing end is smooth and free of burrs and abrasions. Lubricate the end of the tube with water or a light coat of silicone and push the tube end firmly into the fitting. You should feel it push past the O-ring. Avoid bending the tubing sharply away from the fitting.

Disconnect:

Hold the collar against the fitting body and pull the tube from the fitting. In the unlikely event that the connection leaks, remove and recut the tubing. Check the inside of the fitting for debris or O-ring damage. Reconnect. Push-to-connect tubing connectors grip the outside diameter of the tube. To help assure a reliable connection, it is important to use high quality tubing with a consistent outside diameter.

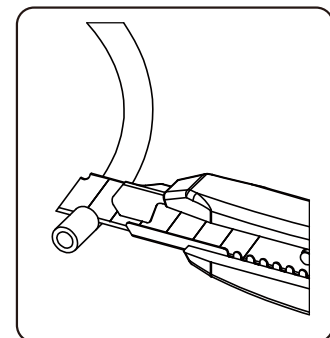

Step-3 Install T-Adapter Valve

1. Turn off the water supply, disconnect the hose pipe. take the inlet 3-way valve out from the accessory bag, install it on the pipe line as the figure 2.

2. Take out the 3/8" tubing from the accessory bag, cut it to proper length, attach one end to the inlet 3-way valve, attach the another end to the "Inlet" port on RO module assembly, make sure the tubings are fully seated.

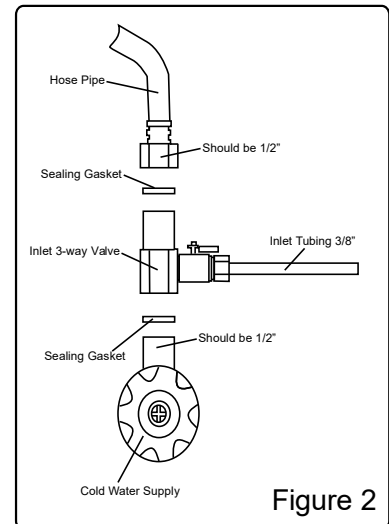

Step-4 Connect System Drain

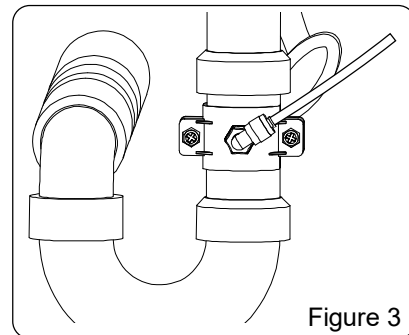

1. Take out the 3/8" tubing from the accessory bag, cut it to proper length, attach one end to the "Drain" port on RO module assembly and attach the another end to the drain pipe line(Figure 3). Make sure the tubings are fully seated.



NOTE

The installation figures above are only for reference, it may vary from different installation sites and conditions.

Step-5 Install Filter Cartridges

1. Take out the filter cartridges from the carton box.
2. Insert the CPF Cartridge in lowest hole, the triangle icon on top of filter element should be pointed at the  icon(Figure 4).
3. Gently press the filter element and rotate it 90° clockwise, ensure the triangle icon on top of filter element point at  icon(Figure 5).
4. Follow step 2 and 3 to install the RO filter cartridge and CTO filter cartridge.

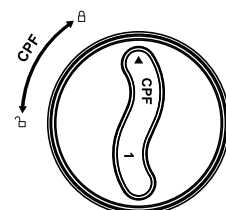
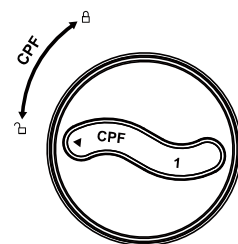

Step-6 Start-Up Instructions

1. Check system to verify all components are correctly installed.
2. Open inlet valve, connect to water supply.
3. Plug in power cord, connect power on.
4. Open the faucet and let the water flow through each filter elements.
5. Flush the filter elements for around 10 minutes. It is normal to see black carbon fines in water.
6. Check system thoroughly for leaks. If any are found, shut off both inlet and power, then correct the issue.
7. After flushing process, close the faucet to make sure the boost pump stops working.
8. Reset the filter elements life following the instructions on Page 17.
9. As all above is done correctly, your RO system is ready to use.



CAUTION

Do not drink water produced by the system until the Start-Up procedure has been followed completely!

LED DISPLAY & TOUCH KEYS PROGRAMMING GUIDE

As the power is on, the display will flash 3 times and then system will automatically flush itself for 30 seconds. Display will automatically light off if no key is operated in 5 minutes. Then system enters Power Saving Mode, press any key to light on the display.

In the event of System Error, Leakage Detected or Filter Life Expired, display will always on and not enter Power Saving Mode.

"Select" Key Used For: 1) Select the desired filter element to reset filter life.
2) Press and hold "Select" key for 3 seconds to have an automatic forced rinse.

"Reset" Key Used For: 1) Press and hold "Reset" key for 3 seconds to enter Filter Life Reset programming.
2) Touch "Select" key to select the desired filter element that need to reset life. Press and hold "Reset" key for 3 seconds, filter life is reset.

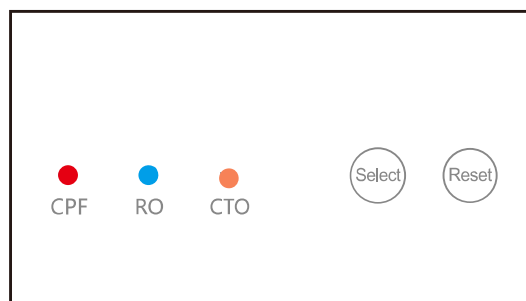

Filter Life Indication:

The filters' life are indicated by 3 LED lights. The lights will display blue color as the system is newly installed. As more water being treated, the filter become exhausted and need to be replaced. At this time, the light will display orange or red color. But the system still can work and will not stop the pump.

As the duration of one filter element reached to its 90% designed life. The light color turn to orange.

As the filter element reached to its 100% designed life, the light color turn to red.

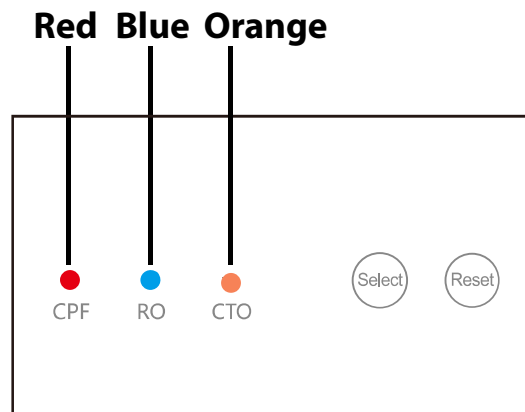

Types of Filter Element Flush:

1.Power on: RO system will automatically have a rinse for 30 seconds when the power is supplied.

2.Forced: Press and hold "Select" key for 3 seconds, RO system will automatically have a rinse for 60 seconds.

3.Accumulated: As the duration of producing water accumulated to 3 hour, system will automatically have a rinse for 30 seconds. If any forced rinse was operated in this period, the accumulated duration of producing water will be reset.

4.After Producing Water: If the system produces water continuously more than 5 minutes and there is no flushing happened during this time, after the faucet is closed, it will automatically rinse for 18 seconds.

How to Reset Filter Elements Life?

1. Press and hold "Reset" key for 3 seconds to enter Filter Element Reset program.
2. Touch "Select" key to choose the filter element you are ready to reset life.
3. Press and hold "Reset" key for 3 seconds, after that you will hear two times beep sound, that means the filter element life is reset successfully.

NOTE

In the process of filter reset, if no key is operated for 10 seconds, system will exit Filter Element Reset program.

SERVICE AND MAINTENANCE

Service Schedule

To keep the RO system operating properly, it is necessary to change the filter elements periodically. Typically, this should be done on an annual basis. Service frequency may vary depending on local water conditions. High sediment, chlorine, turbidity, or hardness levels may require more frequent service.

Use the Following as a Guide:

Filter Elements	Service Schedule
CPF Filter	12 months
RO Filter	24 months
Post Carbon Filter	12 months

Note: Filter life may vary greatly depend on different water quality, RO filter life will be affected by other factors. The service schedule above is only for reference.



NOTE

RO-UX5 is designed only for household use, do not install the system where the water usage demand is high.

Filter Element Should Be Replaced If Following Situations Occur:

1. Produced water quality is poor, taste bad.
2. Product water rate decrease dramatically, CPF filter or RO membrane may clog. (Make sure it is not caused by cold water temperature)
3. Filters are heavily clogged, almost no produced water.

How to Replace Filter Elements?

1. Close the T-adaptor valve to shut off water supply.
2. Open the faucet to release pressure.
3. Turn off power supply.
4. Rotate the old filter element for 90° anti-clockwise quickly, as the triangle icon on top of filter element pointed at  icon, take out the old element(As Figure 6).
5. Insert the new filter element into the correct hole of filter manifold, the triangle icon on top of filter element should be pointed at the  icon.
6. Gently press the filter element and rotate it 90° clockwise, ensure the triangle icon on top of filter element point at  icon(As Figure 7).
7. Turn on the power and water supply.
8. Follow the instructions on **Page 17** to reset filter element life.
9. Flush the new installed filters for 5~10 minutes.
10. Filter element replacement complete.

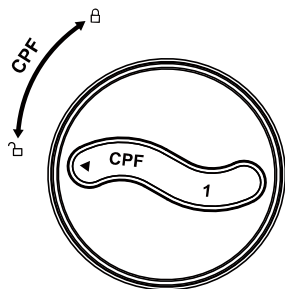

Figure 6

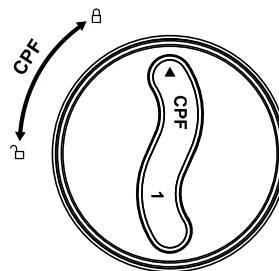

Figure 7

	CAUTION	Always follow the steps below prior to replace the filters.
---	----------------	---

- 1. Shut off water supply.** → **2. Open the faucet.** → **3. Turn off power supply.**

Application Notes:

- 1.Product Water Rate:** Product flow are variable and can be effected by water temperature and pressure. The product flow rate stated in the performance data sheet is tested at standard conditions.
- 2.Disposal of Replaced Filter Element:** The replaced filters can not be recycling and reusing, it is recommended to discard it as household garbage and let professional garbage recycler to treat it.
- 3.**When you are on vocation or not using the system for a long time, please close the T-adaptor valve and turn off power supply.
- 4.**Any of the following occurs, please shut off the water supply and power supply immediately and fix the issue.
 - 4.1 Leakage is found somewhere.
 - 4.2 System's componet is malfunctioning.
 - 4.3 Electric leakage is found somewhere.
 - 4.4 Any other abnormal situation or faulty.

TROUBLE SHOOTING GUIDE

Problem	Possible Solutions
<p>1. Pump Not Running, No Product Water</p> <p>A. Power supply is not on. B. Transformer is damaged. C. Filter element life expired. D. Leakage is detected by system. E. System continuously produces water for 30 minutes. F. Low incoming water pressure. G. Low pressure switch is malfunctioning, power is not switched to pump. H. High pressure switch is malfunctioning and not reset itself. I. Pump is damaged.</p>	<p>A. Plug in the power supply or wait for restore power. B. Replace the transformer C. Replace filter element. D. Check the leakage and remedy it. E. Unplug the power and replug it. F. Increase incoming water pressure to allow low pressure switch on. G. Repair low pressure switch or replace it. H. Repair high pressure switch or replace it. I. Replace the pump.</p>
<p>2. Pump Continuously Running.</p> <p>A. Pump is malfunctioning. B. High pressure switch is malfunctioning.</p>	<p>A. Replace the pump. B. Repair high pressure switch or replace it.</p>
<p>3. Pump Continuously On & Off .</p> <p>A. Low incoming water pressure. B. Low pressure switch is malfunctioning. C. High pressure switch is malfunctioning. D. Leakage happens somewhere in system.</p>	<p>A. Increase incoming water pressure. B. Repair low pressure switch or replace it. C. Repair high pressure switch or replace it. C. Find the leakage and fix it.</p>
<p>4. Not Enough Product Water</p> <p>A. Feed water valve is plugged or closed. B. Sediment/Carbon prefilter or Carbon Post Filter is clogged. C. Low incoming water pressure. D. Reverse Osmosis Membrane is fouled. E. The Faucet is out of adjustment or faulty. F. No water to drain. Drain Flow Restrictor is clogged.</p>	<p>A. Open valve or unclog. B. Replace filters. C. Increase incoming water pressure. D. Make sure incoming water pressure is within operating limits. Make sure drain line is not clogged. Correct cause of fouling and replace RO Membrane. E. Repair or replace Faucet. F. Replace flush solenoid valve.</p>
<p>5. Product Water is High in TDS</p> <p>A. Clogged Prefilter. B. Reverse Osmosis Membrane is expended. C. Product water and drain water lines are reversed. D. No water to drain. Drain Flow Restrictor is clogged. E. New Carbon Postfilter has not been rinsed completely. F. The incoming feed water TDS has increased.</p>	<p>A. Replace Filter. B. If Membrane life is unusually short, find and correct the problem. (Average life is 2 years.) Replace RO Membrane. C. Correct plumbing. D. Replace flush solenoid valve. E. Open the faucet and flush the post carbon filter for 10 minutes. F. An increase in feed water TDS will also give an increase in Product Water TDS.</p>
<p>6. Tastes and Odors in Product Water</p> <p>A. Carbon Post Filter is exhausted. B. Product water and Drain water lines are reversed. C. Increase in Product Water TDS.</p>	<p>A. Replace Post Carbon Filter. B. Correct plumbing. C. Replace RO Membrane.</p>
<p>7. Faucet Leaks or Drips</p> <p>A. Water leaks from faucet spout.</p>	<p>A. Repair or replace the faucet.</p>
<p>8. External Leakage on Connection</p> <p>A. Tubing not fully seated in fitting. B. Tubing abraded in seal area. C. O-rings sealing aging.</p>	<p>A. Check all fittings for tightness. B. Recut tubing and redo connection. C. Replace the O-rings.</p>